

How to fold your MGB top (post 1970 folding hood)

(Reprinted from The Octagon, Volume 48, Number 2 - Summer 2004)

It is most important that the instruction for raising, lowering and folding the hood are followed closely.

CAUTION: Do not fold the hood when it is wet or damp. Always ensure that the rear window is zippered in position before attempting to lower the hood.

Figure 1

Unclip the sun visors (1) and move them to one side. Release both windscreen frame toggle catches (2). Release the two fasteners (3) on the windscreen rails, the two fasteners (4) on the cant rails and the two fasteners (5) on the hood mounting brackets.

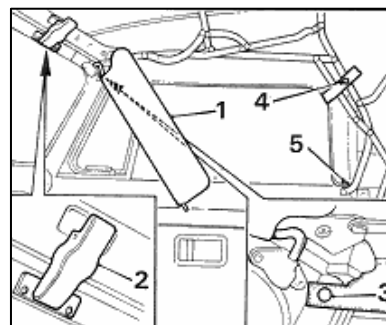

Figure 1

Figure 2

Release the four fasteners from each rear quarter panel (6) and pull the hood slightly forward to disengage the hook (7) from the socket (8) on the body side panel. Move the seat tilt catch forward and incline the seat backs towards the front of the car.

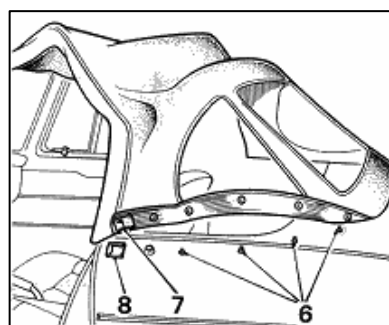

Figure 2

Figure 3

Raise the hood header rail (11) until it is poised approximately midway over the door aperture. Disengage the hood rear rail from the anchor plates (9) on the tonneau panel. Fold each quarter-light (10) onto the back-light and continue the fold in the material forward to the header rail (11). Push the header rail (11) rearwards and at the same time draw the back-light and the hood material (12) out over the luggage compartment lid ensuring that the hood material does not become trapped between the hood sticks.

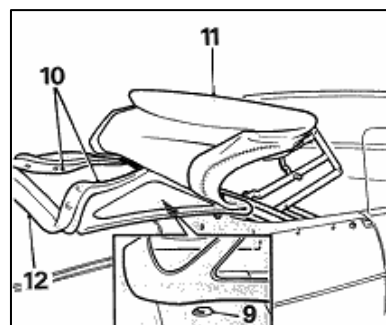

Figure 3

Note: Ensure that the fold is made in the material between the quarter light and the back-light. Failure to do this may cause permanent damage to the back-light material.

Editors Note: It is a good idea to place an old towel into the folded hood first, as extra insurance against scratching the plastic windows.

Figure 4

Fully lower the hood. Fold the two windscreen frame toggle catches (13) rearwards to prevent them from damaging the back-light. Roll the rear window and the hood material forward over the folded hood. Position and secure the two retaining straps (14). Replace the sun visors and return the seat back-rest to their original positions. Fit the hood cover or tonneau cover in position.

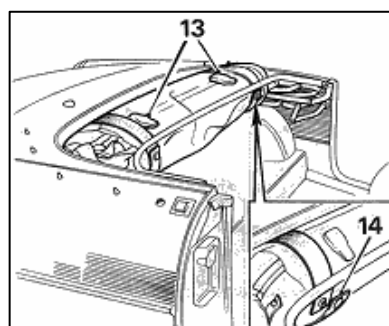

Figure 4

Credit:

Transcribed from *The Complete Official MGB 1975-1977*; Robert Bentley, Inc.; Cambridge, Mass; pp. 14-15.
Figures and text copyright British Leyland Motor Corp., 1975, 1977